

GENERAL TOLERANCES FOR DIMENSIONS WITHOUT TOLERANCE INDICATIONS				TOLERANCE SYSTEM ACC. TO ISO	
MACHINING ISO 2768	f	m	c	v	
	FINE	MEDIUM	COARSE	VERY COARSE	
WELDING ISO 13920	A	B	C	D	
	FINE		COARSE		

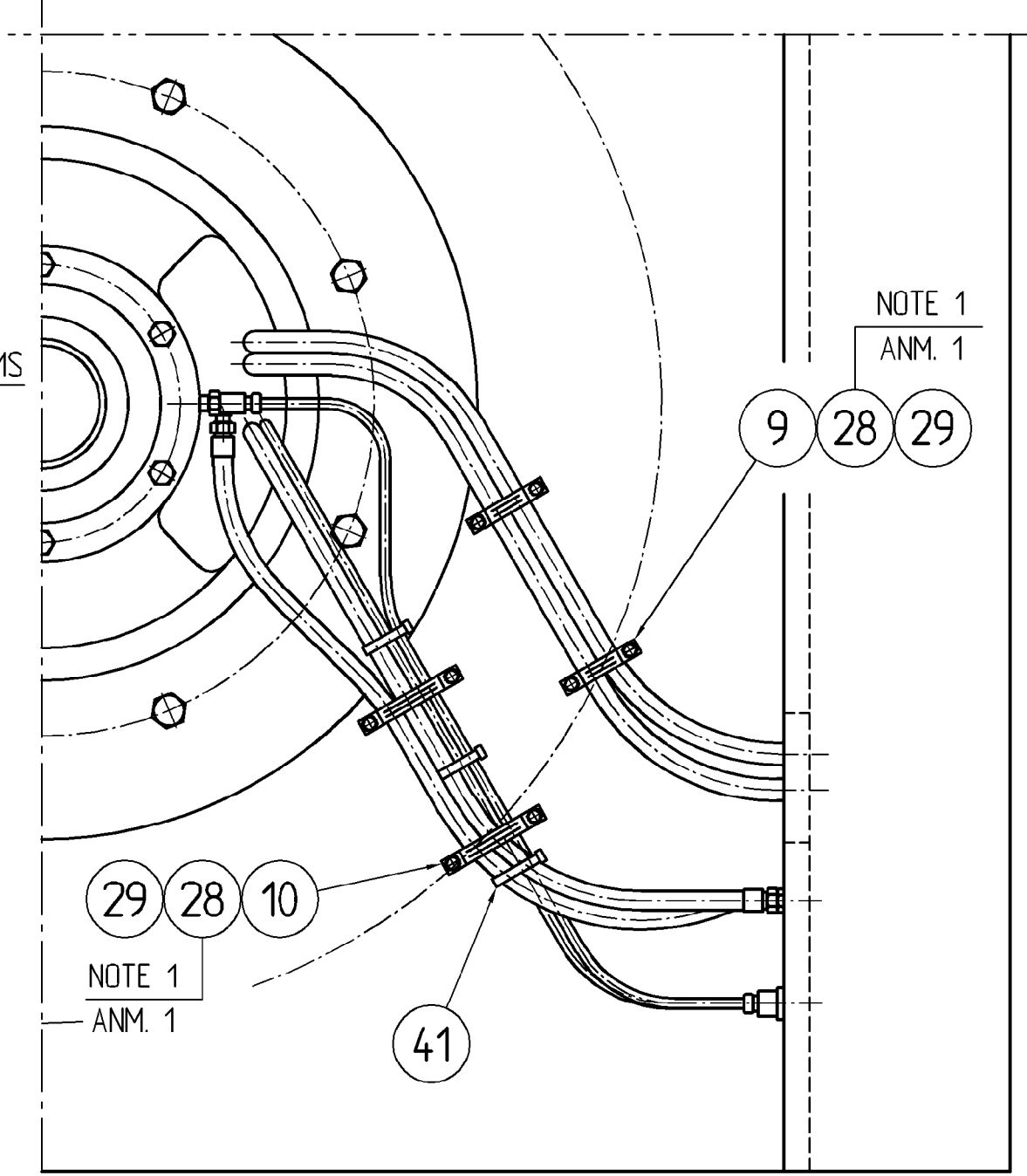

- NOTE
- DRILL AND THREAD M6 (8x) AT ASSEMBLY OF POS. 9 AND 10
 - LUBRICATION CONNECTION BOTTOM BEARING.
 - MEASURING CONNECTION BOTTOM BEARING TEST MOUNTED, DELIVERED NOT MOUNTED.
 - TEST MOUNTED, DELIVERED NOT MOUNTED.
 - MOUNTED ON OPPOSITE SIDE OF FRAME.
 - NOT TO BE STRETCHED SO THAT PROFILE DECREASES.
 - CHECK THE CLEARANCE 1 mm AND IF NECESSARY PUT SHIMS UNDER THE HOLDER FOR SCREEN CYLINDER.
 - LOCKED WITH LOCTITE 243
 - GUIDE PIN (1x) FOR CORRECT MOUNTING OF SCREEN CYLINDER.

- ANM.
- BORRA OCH GÅNGA M6 (8x) VID MONTAGE AV POS. 9 OCH 10
 - SMÖRJANSLUTNING NEDRE LAGER.
 - MÄTANSLUTNING NEDRE LAGER.
 - PROVMONTERAD, LEVERERAS LÖST.
 - MONTERAS PÅ MOTSA TT SIDA STATIV.
 - FÅR EJ STRÄCKAS SÅ ATT PROFLEN MINSKAR.
 - KONTROLLERA SPELET 1 mm OCH VID BEHOV LÄGG MELLANLÄGG UNDER HÅLLARE FÖR SILCYLINDER.
 - LÄSES MED LOCTITE 243.
 - STYRPINNE (1x) FÖR KORREKT MONTAGE AV SILCYLINDER.

ITEM NO./DOC NO	POS NO	QUANT	DESCRIPTION	DESIGNATION/DIMENSIONS/MATERIAL/DRAWING	NET WEIGHT TST. ADF. KG
REFERENCE		CUSTOMER'S DRG. NAME		SDU0003213_01	DOC CODE SYSTEM
SUPERSEDES		OWNER GROUP		UCENKDCEN	AutoCAD
WEIGHT kg	LANGUAGES		SCALE	DRAWN	DATE
	EN / SV		1:5	SDUJAJU	2005-06-16
ASSEMBLY DRAWING	SAMMANSTÄLLNINGSRITNING		CHECKED	SDUJAJU	2005-06-16
BASE MACHINE	BASMASKIN		APPROVED	SDUANBE	2005-07-07
PRODUCT	DT4		DOCUMENT ID	SDU0003213	SHEET 1/1
					REVISION 01

THE INFORMATION CONTAINED HEREIN IS UNCLASSIFIED CONFIDENTIAL INFORMATION AND SHALL NOT BE REPRODUCED IN ANY MANNER OR DISCLOSED TO ANY THIRD PARTY WITHOUT THE PRIOR WRITTEN CONSENT OF METSO PAPER, INC. OR ITS SUBSIDIARY COMPANY.